

Welding - TIG

Zack Brown

zbrown@visalia.k12.ca.us

El Diamante High School

CHECK IN: 8:30 am CONTEST BEGINS: 9:00 am

LOCATION: El Diamante High School Agriculture Department, 5100 W. Whitendale, Visalia

CLASS:

1. TIG competition

ELIGIBILITY:

Limited to 8 students per high school in TIG welding. Refer to the General Information and Rules page.

SCOPE OF CONTEST:

1. TIG Welding to be done with 1/8".
Material: **1/8" x 2" x 6"** plates.
 - Tee -Flat
 - Butt -Flat
 - Lap -Flat
 - Corner -Flat
2. Students must bring their own helmet, goggles, gloves, leathers and safety glasses.
3. Safety glasses, long sleeve shirts, and long pants must be worn at all times when in the welding lab. Anyone wearing shorts or tank tops will not be admitted.
4. Students **MUST** leave the welding lab upon completion of his/her competition to make room for the next student.

EQUIPMENT AND MATERIALS:

Aside from the items listed above, all material and equipment will be supplied by the chairperson. Test plates will be stamped, tacked and ready to weld.

TIME:

Roll will be taken at 9 a.m.

SCORECARD:

TIG WELDING

TIE BREAKER:

In case of a tie, contestants will be presented with the same designated type of weld to perform on which they will be judged.

TIG Welding Competition

TIG (GTAW) Welding Competition

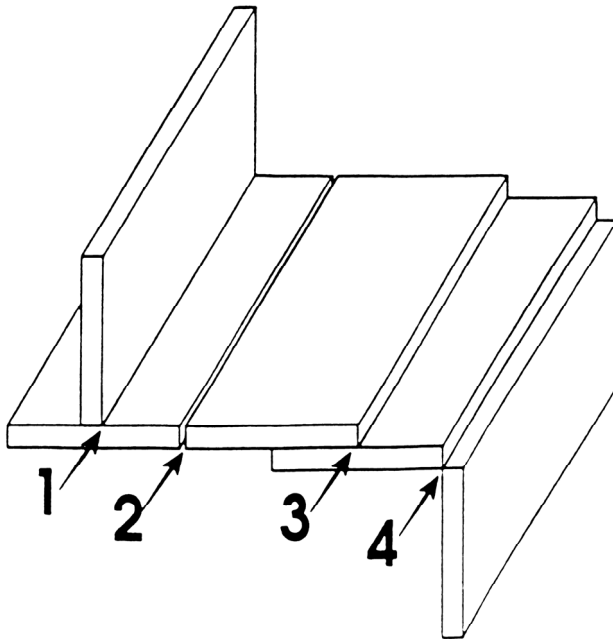

MATERIALS:

1. 1/8" ga 2" x 6"
2. All material will be tacked and ready to weld.
3. Materials will be supplied.

WELDS:

3/32" STEEL FELLER:

All welds Flat