

Welding – Arc / Gas

CHECK IN: 8:30 am CONTEST BEGINS: 9:00 am

CLASS:

1. Arc Welding competition
2. Gas Welding competition

ELIGIBILITY:

Limited to 4 students per high school in arc welding and 4 students per high school in gas welding. Refer to the General Information and Rules page.

SCOPE OF CONTEST:

1. Arc Welding to be done with 1/8" -6011 rod on AC or DC.
Material: **3/16" x 2" x 6"** plates.
 - Tee -Vertical up
 - Butt -Flat
 - Lap -Horizontal
 - Corner -Flat
2. Gas Welding to be done with 3/32" Steel and Bronze, flux coated rods.
Material: **14 ga 2" x 6"** plates.
 - A. Steel Rod
 - Corner -vertical up
 - Butt -flat
 - B. Bronze Rod
 - Tee -flat
 - Lap -flat
3. Students must bring their own helmet, goggles, gloves, leathers and safety glasses.
4. Students will be limited to gas or arc. A student CANNOT compete in both arc and gas.
5. Safety glasses, long sleeve shirts, and long pants must be worn at all times when in the welding lab. Anyone wearing shorts or tank tops will not be admitted.
6. Students MUST leave the welding lab upon completion of his/her competition to make room for the next student.

EQUIPMENT AND MATERIALS:

Aside from the items listed above, all material and equipment will be supplied by the chairperson. Test plates will be stamped, tacked and ready to weld.

TIME:

Roll will be taken at 9 a.m.

SCORECARD:

ARC WELDING and GAS WELDING

TIE BREAKER:

In case of a tie, contestants will be presented with the same designated type of weld to perform on which they will be judged.

Welding Competition

Arc Welding Competition

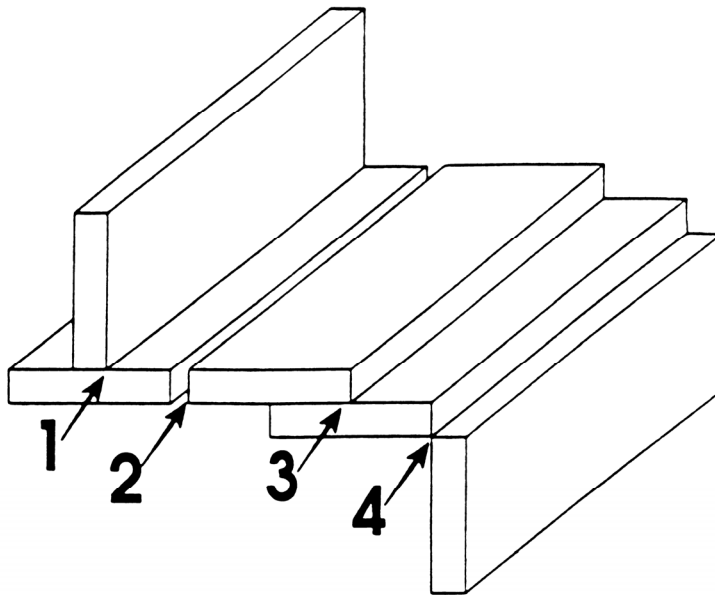

ELECTRODE: 1/8" – 6011

MATERIALS:

1. 3/16" x 2" x 6" plate
2. All materials will be tacked and ready to weld.
3. Materials will be supplied.

WELDS:

1. Vertical Up
2. Flat Butt
3. Horizontal Lap
4. Flat Corner

Gas Welding Competition

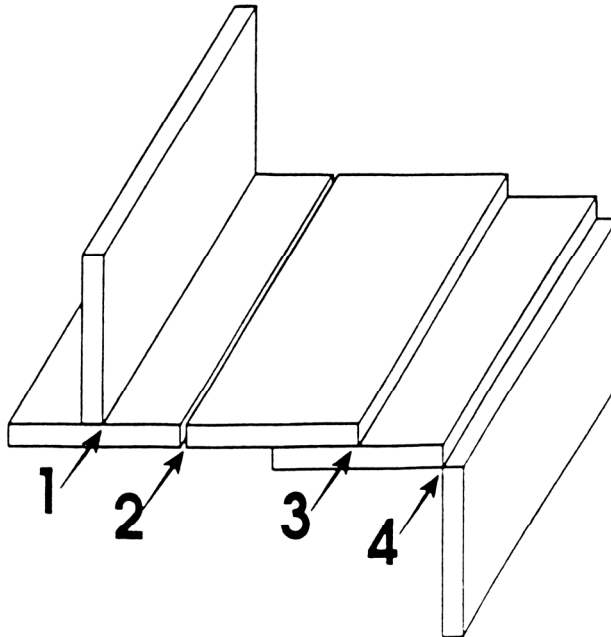

MATERIALS:

1. 14 ga 2" x 6"
2. All material will be tacked and ready to weld.
3. Materials will be supplied.

WELDS:

3/32" STEEL FELLER:

2. Flat Butt
4. Vertical Up Corner

3/32" BRONZE FELLER:

1. Fillet-Flat
3. Lap-Flat